

94020 Conservation Vent (Pressure & Vacuum)

The Shand & Jurs Model 94020 Conservation Vent is designed utilizing over 90 years of experience in producing high quality and dependable conservation fittings. Continued design improvements provide these vents with high efficiency, maximum flow capacity and minimum leakage. The easily serviceable configuration and lightweight construction reduces maintenance and installation costs.

A variety of construction materials are available as part of the standard design which are ideally suited for highly corrosive and toxic product applications. Aluminum, 316 Stainless Steel or Carbon Steel body vents comes standard with integral seats or optional replaceable seats. Cast Iron and Ductile Iron bodies only with 316 SS replaceable seats.

The standard FEP diaphragm is "Air Cushion Seated" for high resistance to adhesion of ice and gum formation thus assuring protection against pallet sticking to the seating surface. The body is self-draining towards the inlet which keep condensates from the seating surfaces. The carefully engineered body, seat, and pallet assembly results in a superior combination of tight sealing and high capacity at low over-pressure with minimal blow down.

Conservation Vents are available in a full range of sizes and configurations, such as open vent, closed vent (pipe-away), cryogenic hoods and flame snuffers. Standard pressure and vacuum settings are 0.5 oz/in². The 94020 Conservation Vent is available with optional pressure and vacuum limit switches and visual indicators.

Expanda-Seal

Shand & Jurs "Expanda-Seal" option is available on all pressure pallet assemblies. This feature significantly reduces leakage. The ballooning effect of the FEP Diaphragm effectively seals the valve.

The "Expanda-Seal" feature ensures less than 0.5 SCFH of air at 95% of the set point.

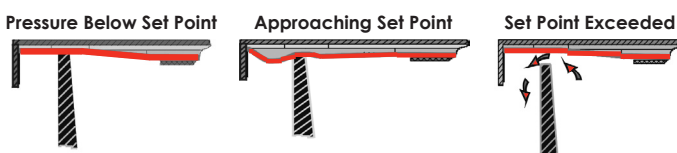

Open Vent



Closed Vent

Features

- Suitable materials available for corrosive/extreme temperature service
- Pallet reaction lip for smooth lift and reseating
- Vertical lift pallets assure reliable operation and maximum flow
- Floating diaphragm results in a positive seal and minimal blow-down
- "All weather" coating, insulation jackets and steam jacketing options available
- Capacity certified to API Standards

Conservation Vent Specifications:**Sizes:**

2", 3", 4", 6", 8", 10" & 12"

Settings:Standard Pressure & Vacuum: 0.5 oz/in²
(.865 in. W.C.)**Maximum Setting W/O Modification:**

	(Pressure)	(Vacuum)**
2":	12 oz/in ²	8 oz/in ²
3":	12 oz/in ²	9 oz/in ²
4":	12 oz/in ²	11 oz/in ²
6":	10 oz/in ²	10 oz/in ²
8":	8 oz/in ²	8 oz/in ²
10":	6 oz/in ²	6 oz/in ²
12":	5 oz/in ²	5 oz/in ²

Expanda-Seal Pressure Setting:1.5 oz/in² Minimum (Consult Factory for lower settings)**Temperature Range:**Process Temperature ranges for body material:
-65°F to 250°F (Aluminum)
-65°F to 350°F (316 Stainless Steel)
-20°F to 350°F (Carbon Steel)
-20°F to 325°F (Iron)**Type of Flange Connection:**Screwed or flanged for: 2" & 3" sizes
Flanged for: 4", 6", 8", 10" & 12" sizes
Raised face flange available, except for aluminum body material.**Options Available:**

Flame Snuffer for all sizes (open vent) and material, except low temperature service. Closed vent for all sizes and materials. Material substitutions as required. Cleaning for LOX/LIN service.

NOTES:

** Modifications may be required to vacuum port for installations where product contamination may occur. See figure 4 for Principle of Operation. Caution—any obstruction to vacuum port may alter the set point.

Materials of Construction**Body:**

Cast Aluminum, Cast Steel, Cast Iron, Ductile Iron or 316 Stainless Steel

Closed Vent Cover:

Aluminum, Steel or Stainless Steel

Pallet/Retainer:

Aluminum or 316 Stainless Steel

Seat:

Aluminum or 316 Stainless Steel

Stem Guide:

Galvanized Steel, Galvanized Iron or Stainless Steel

Screen:

Galvanized Steel or Stainless Steel

Diaphragm:

FEP (Fluorinated Ethylene Propylene), FKM (Fluoroelastomer), NBR (Nitrile-Butadiene), PFA (Fluoroplastic Film)

Back-up Disc:

Fiber, Glass Filled Teflon (GPTFE)

Closed Vent Cover Gasket:

Fiber, Glass Filled Teflon (GPTFE), FKM, NBR

Standard Materials of Construction

Component	Normal Aluminum	Low Temperature*	Severe		
Body	Cast Aluminum	Cast Aluminum	Cast Iron/Ductile Iron	Cast Steel	316 Stainless Steel
Cover	Aluminum	Aluminum	Carbon Steel	Carbon Steel	316 Stainless Steel
Hood	18-8 Stainless Steel ¹	Aluminum ²	18-8 Stainless Steel ¹	18-8 Stainless Steel ¹	316 Stainless Steel
Seats ³	Aluminum	Aluminum	316 Stainless Steel	C.S. with 316 SS Overlay	316 Stainless Steel
Stem Guide	Galvanized Iron	Galvanized Iron	304 Stainless Steel	304 Stainless Steel	316 Stainless Steel
Pallets	Aluminum	Aluminum	316 Stainless Steel	316 Stainless Steel	316 Stainless Steel
Distribution Plate ^{4,5}	Aluminum	Aluminum	Carbon Steel	Carbon Steel	316 Stainless Steel
Pressure Stem	316 Stainless Steel	316 Stainless Steel	316 Stainless Steel	316 Stainless Steel	316 Stainless Steel
Vacuum Stem	Aluminum ⁶	Aluminum ⁶	316 Stainless Steel	316 Stainless Steel	316 Stainless Steel
Screens	Galvanized Steel	Galvanized Steel	304 Stainless Steel	304 Stainless Steel	316 Stainless Steel
Retainer	Aluminum	Aluminum	316 Stainless Steel	316 Stainless Steel	316 Stainless Steel
Hardware	Zinc Plated Steel	Zinc Plated Steel	316 Stainless Steel	Zinc Plated Steel	316 Stainless Steel
Diaphragms	FEP	FEP	FEP	FEP	FEP

NOTES: 1. 18-8SS for 2", 3", 4", 6" & 8" sizes; spun alum. for 10" & 12" sizes.
 2. 2", 3", 4", 6", 8", 10" & 12" sizes ; alum. enclosure w/flapper.
 3. Material same as body except CI and DI.
 4. When Provided

5. SS weights option includes SS distribution plate
 6. 316SS for elevated settings.
 7. For Cryogenic Service, must add Stainless Steel Trim on Table H, Option 5, 6 or 7

Principle of Operation

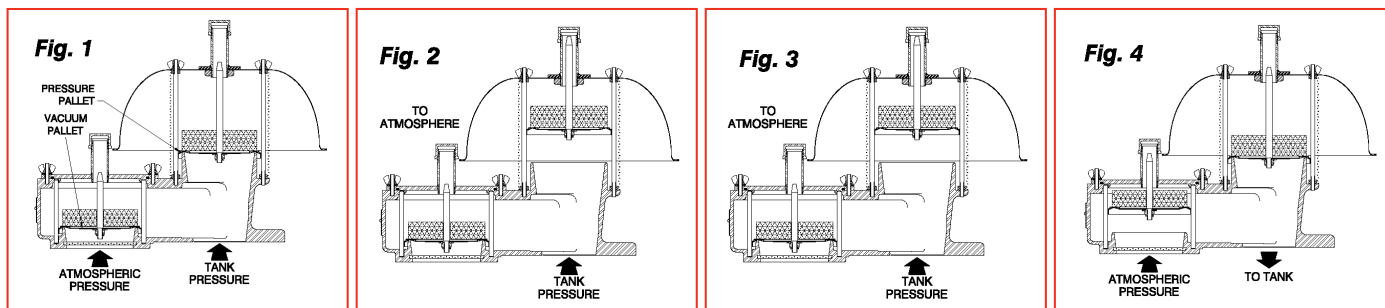

Figures 1 and 3 show the relation of the pressure or vacuum pallet assembly to the seat when atmospheric and tank pressures are equal. The "wrap around" effect of the resilient diaphragm on the edge of the seat and the resulting high ratio of seating force to seating area affords a tight seal.

As the pressure or vacuum increases, the pallet begins to rise. Because there is still a wrap-around effect on the edge of the seat, good sealing is maintained. FEP diaphragm memory and lapped seating surface further enhance sealing characteristics.

As increasing pressure or vacuum continues to lift the pallet, the diaphragm is held in close proximity to the seat by the flat plane memory of the diaphragm material.

As set pressure or vacuum is reached the diaphragm leaves the seat (see Figures 2 and 4) and the escaping vapor lifts the pallet even further.

The vacuum pallet is guided in the same manner as the pressure pallet. Both are pallet stem and pallet side guided for smooth movement.

94020 Closed Vent

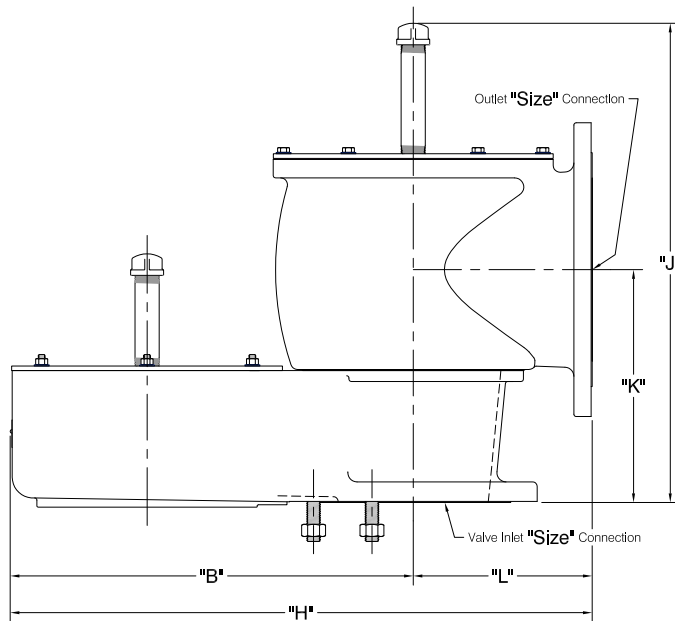

*Table D option 5 for same size inlet and outlet connections has been obsoleted and replaced by Table D option 6. Dimensions do not match. Consult Factory for replacement valve.

Valve Size	Outlet Size	"H"	"J"	"K"	"L"	"B"
2"	2"	13	11 1/8	5 1/32	4 1/4	8 3/4
2"	3"	13	11 1/8	5 1/32	4 1/4	8 3/4
* 3"	3"	16 3/8	13 1/4	5 9/16	5 1/4	11 1/8
3"	4"	16 3/16	13 3/4	5 31/32	5 1/4	10 15/16
* 4"	4"	20	20 3/8	7	6 1/2	13 1/2
4"	6"	19 1/4	15 3/4	7 1/32	5 15/16	13 5/16
* 6"	6"	26 1/4	21 1/4	9 3/8	8 3/8	17 7/8
6"	8"	26 3/16	21 1/4	10 11/32	8 1/4	17 15/16
* 8"	8"	31 5/8	25 1/2	11 11/16	9 3/4	21 7/8
8"	10"	31 5/8	26 3/16	12 23/32	9 3/4	21 7/8
* 10"	10"	37 7/8	30	13 7/8	11 19/32	26 9/32
10"	12"	37 7/8	30 1/4	14 29/32	11 19/32	26 9/32
* 12"	12"	43 3/8	33 7/8	16 1/4	12 13/16	30 9/16
12"	14"	43 3/8	33 7/8	16 29/32	12 13/16	30 9/16

NOTES:

1. Connection size matches ANSI, EN1092-1 & JIS.
2. **Mounting Holes straddle centerline except: 2" & 3" sizes; holes are on centerline.**
3. Optional NPT Adapter available for 2" & 3".
4. Dimensions expressed in inches.
5. Raised faced flanges with smooth finish are standard. For optional serrated raised faced flanges, consult factory.

94020 Open Vent

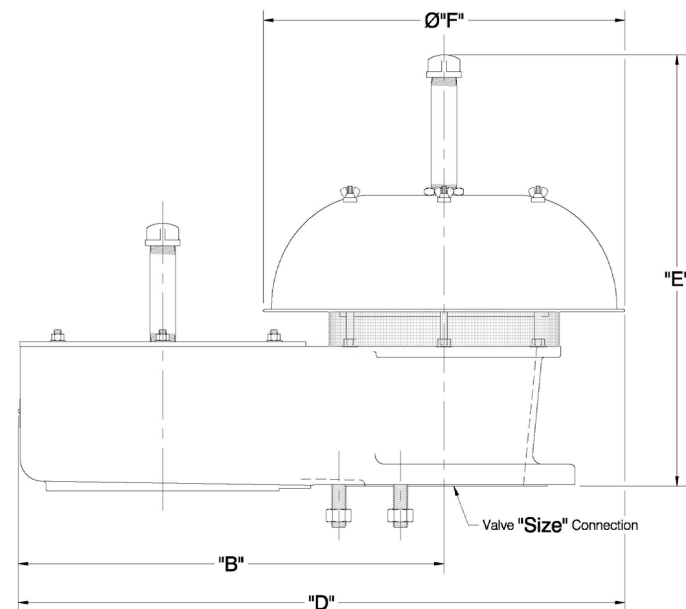

Valve Size	"B"	"D"	"E"	Diameter "F"
2"	9	15 1/4	11 1/8	12 7/8
3"	11 1/8	17 15/16	13 3/4	13 9/16
4"	13 1/2	21 1/2	15 3/4	15 15/16
6"	17 15/16	28 1/2	18 3/4	18 5/8
8"	21 7/8	31 3/16	21 1/4	18 5/8
10"	26 1/4	40 5/8	28 1/8	25 9/16
12"	30 9/16	44 5/8	32 1/4	29 7/8

NOTES:

1. Connection size matches ANSI, EN1092-1 & JIS.
2. **Mounting Holes straddle centerline except: 2" & 3" sizes; holes are on centerline.**
3. Optional NPT Adapter available for 2" & 3".
4. Dimensions expressed in inches.
5. Raised faced flanges with smooth finish are standard. For optional serrated raised faced flanges, consult factory.

All designs subject to change. Certified dimensions and specifications available upon request

6", 8", 10" & 12" Cryogenic Hood Model

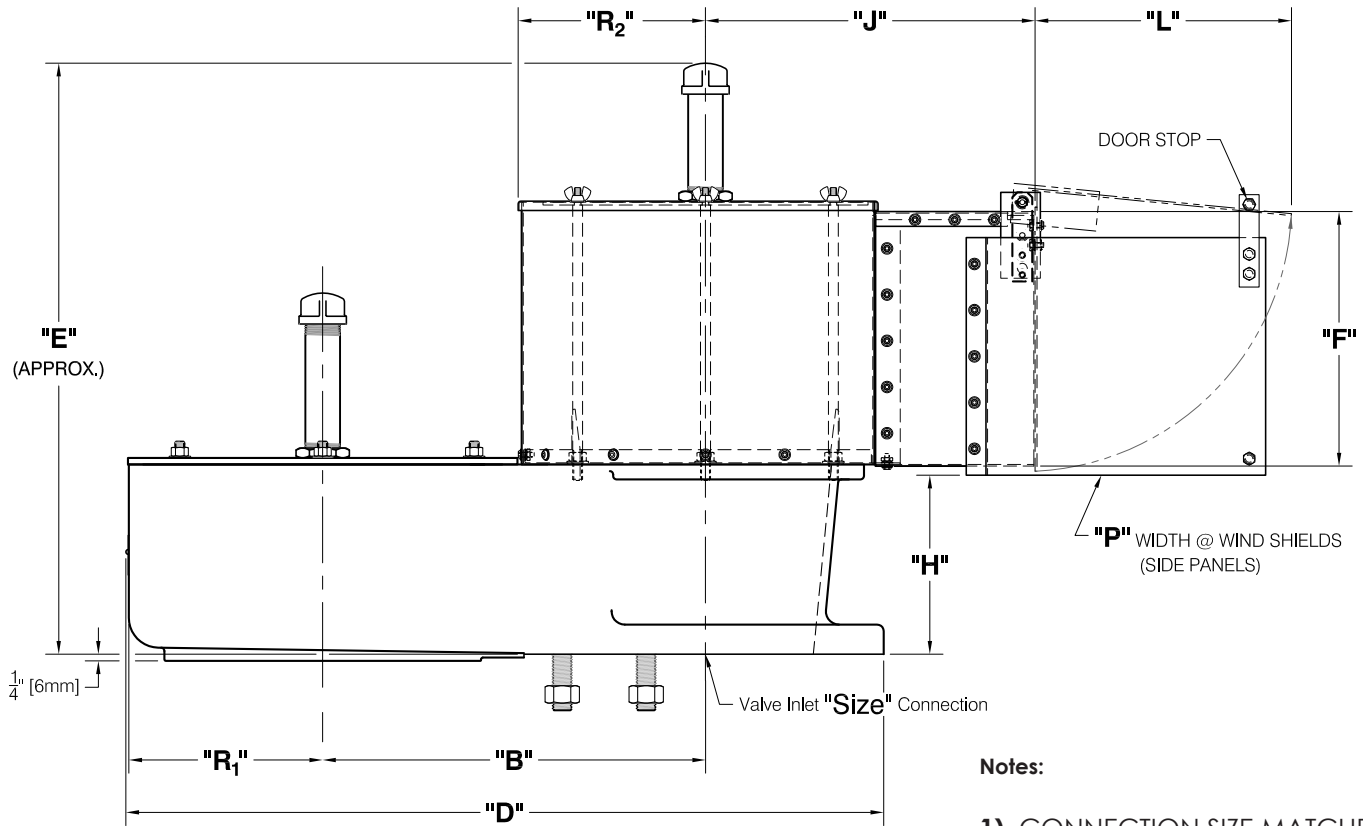

Notes:

- 1) CONNECTION SIZE MATCHES 125#FF ANSI, EN1092-1 FLANGE. 150
- 2) MOUNTING HOLES STRADDLE CENTERLINE.
- 3) DIMENSIONS EXPRESSED IN INCHES.

Vent Size* (In.)	Dimensions in Inches									
	"B"	"D"	"E"	"F"	"H"	"J"	"L"	"P"	"R ₁ "	"R ₂ "
6"	11 3/4	27 1/4	18 3/4	8 1/8	5 5/8	11 1/2	8 1/2	11 5/8	R6 1/16	R5 21/32
8"	14 1/2	31 9/32	22 1/8	9 5/8	6 23/32	12 1/2	9 3/4	14 7/8	R7 11/32	R7 1/32
10"	17 1/2	39 3/16	28 1/2	11 3/8	8 1/8	14 3/16	11 3/8	17	R8 3/4	R8 11/32
12"	20 5/8	45 11/16	32 1/4	12 5/8	9 3/4	15 13/32	12 1/2	19 7/16	R9 7/8	R9 21/32

94020 Ordering Guide

Conservation Vents provide tank venting and breathing with high efficiency, maximum flow capacity and minimum leakage. Standard materials of construction include low copper aluminum, cast iron, ductile iron, cast steel, and 316 Stainless Steel. The 94020 comes in open or closed vent versions, and in sizes 2" through 12". Cryogenic hoods, flame snuffers, limit switches and steam jacketing and steam tracing are available.

Benefits

- Low copper aluminum alloy construction reduces need for special materials in corrosive and extreme temperature service
- Capacity certified in accordance with API standards
- Expanda-Seal diaphragm for reduced leakage
- Unique floating diaphragm construction assures positive seal and minimal blowdown, thus conserving valuable tank content
- Peripheral and stem guided pressure pallet assures smooth lift and closure

Model Number Selection

The model number will have a base number 94020 followed by 8 digit numbers.

94020 - AB - CD - EF - GH

*NOTE: If ATEX (A) Unit is required, please use 94020A AB CD EF GH.

If CE (C) Unit is required, please use 94020C AB CD EF GH.

Ordering Information

Specify:

1. Model 94020 Conservation Vent
2. Size and Body Material
3. Screwed or Flanged Connection on 2" and 3" Size
4. Closed Vent or Vent to Atmosphere (With or without flame snuffer)
5. Pressure and Vacuum Settings (if other than normal setting)
6. Type of Cleaning (if for oxygen service)
7. Optional Materials of Construction, as Required
8. To Specify CE for Ordinary EU Locations use 94020C AB CD EF GH
9. To Specify ATEX Certification for Group IIB, IIA EU Locations use 94020A AB CD EF GH. ATEX Certification includes CE Mark.

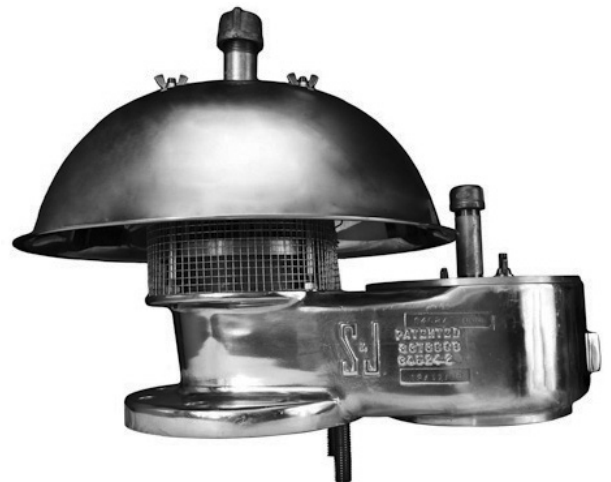

Table AB - Size and Body Material

Option AB	Size	Type of Connection	Body Material
11	2"	NPT	Aluminum
12	2"	Flanged	Aluminum
21	2"	NPT	Alum. Cryo Hood ¹
22	2"	Flanged	Alum. Cryo Hood ¹
*31/41	2"	NPT	Cast Iron/Ductile Iron
*32/42	2"	Flanged	Cast Iron/Ductile Iron
51	2"	NPT	Cast Steel
52	2"	Flanged	Cast Steel
71	2"	NPT	316 Stainless Steel
72	2"	Flanged	316 Stainless Steel
13	3"	NPT	Aluminum
14	3"	Flanged	Aluminum
23	3"	NPT	Alum. Cryo Hood ¹
24	3"	Flanged	Alum. Cryo Hood ¹
*33/43	3"	NPT	Cast Iron/Ductile Iron
*34/44	3"	Flanged	Cast Iron/Ductile Iron
53	3"	NPT	Cast Steel
54	3"	Flanged	Cast Steel
73	3"	NPT	316 Stainless Steel
74	3"	Flanged	316 Stainless Steel
15	4"	Flanged	Aluminum
25	4"	Flanged	Alum. Cryo Hood ¹

*3X = Cast Iron 4X = Ductile Iron
 **For NPT Connections, Specify Table C0

1. **NOTE:** For full Cryogenic Service, must add Stainless Steel Trim

Steam Jacket Option:

Designed for use on tanks containing liquids whose vapors crystallize at ambient temperatures. Stainless steel pressure and vacuum pallets are cased in a steam heated jacket ensuring the valves will be free from plugging. The jacket is steel or stainless steel construction. The standard jacket can withstand steam pressures up to 100 psig. Higher pressure ratings are available.

Table C - Flange Type

Option C	Description
0	ANSI 125/150 lb. FF
1	ANSI 125/150 lb. RF*
2	EN1092-1 PN16 FF
3	EN1092-1 PN16 RF*
4	JIS 10K FF
5	JIS 10K RF*

* RF not available in Aluminum.

** Raised faced flanges with smooth finish are standard. For optional serrated raised faced flanges, consult factory.

Option AB	Size	Type of Connection	Body Material
*35/45	4"	Flanged	Cast Iron/Ductile Iron
55	4"	Flanged	Cast Steel
75	4"	Flanged	316 Stainless Steel
16	6"	Flanged	Aluminum
26	6"	Flanged	Alum. Cryo Hood ¹
*36/46	6"	Flanged	Cast Iron/Ductile Iron
56	6"	Flanged	Cast Steel
76	6"	Flanged	316 Stainless Steel
17	8"	Flanged	Aluminum
27	8"	Flanged	Alum. Cryo Hood ¹
*37/47	8"	Flanged	Cast Iron/Ductile Iron
57	8"	Flanged	Cast Steel
77	8"	Flanged	316 Stainless Steel
18	10"	Flanged	Aluminum
28	10"	Flanged	Alum. Cryo Hood ¹
*38/48	10"	Flanged	Cast Iron/Ductile Iron
58	10"	Flanged	Cast Steel
78	10"	Flanged	316 Stainless Steel
19	12"	Flanged	Aluminum
29	12"	Flanged	Alum. Cryo Hood ¹
*39/49	12"	Flanged	Cast Iron/Ductile Iron
59	12"	Flanged	Cast Steel
79	12"	Flanged	316 Stainless Steel

Table D - Vent Type

Option D	Description
1	Open Vent
2	Open Vent w/ Flame Snuffer
3	Closed, Standard Outlet > Inlet*
6	Pipe Away, Same Size Inlet and Outlet
7	Open Vent with "All Weather" Coating
8	Open Vent with Flame Snuffer with "All Weather" Coating
9	Closed, Standard Outlet > Inlet with "All Weather" Coating
A	Pipe Away, Same Size Inlet, Outlet, Seat with "All Weather Coating"

* Standard closed vent (outlet is one size larger than the inlet).
 Ex. 2" Inlet X 3" Outlet, 6" Inlet X 8" Outlet.

Table E - Pallet / Seal Type

Option E	Pallet Type	Diaphragm
0	Standard	FEP
1	Expand-Seal	FEP
4	Standard	FKM
5	Expand-Seal	FKM
6	Standard	PFA
7	Expand-Seal	PFA
8	Standard	NBR
9	Expand-Seal	NBR

Select seal type material may alter minimum set point.
Air Groove Pallet available only in 316SS with FEP Diaphragm.

Temperature Limits

Diaphragm Material	Temperature Range
FEP	-65°F to 400°F
FKM	-15°F to 400°F
NBR	-40°F to 250°F
PFA	-65°F to 500°F

Table F - Pressure Range & Load Weight Material

Option F	Description	Weight Material
1	**Standard Pressure and Vacuum Setting = 0.5 oz/in ²	Lead
2	Over 2.9 oz/in ² to Maximum Setting	Lead
3	> Standard to 2.9 oz/in ²	Lead
4	**Standard Pressure and Vacuum Setting = 0.5 oz/in ²	316 SS
5	Over 2.9 oz/in ² to Maximum Setting	316 SS
6	> Standard to 2.9 oz/in ²	316 SS
7	Incremental Weights Pressure Only 2.9 oz. - 14 oz. (5 in. W.C. - 24 in. W.C.)	Lead
8	Standard Incremental Weight Set Pressure Only 6" - 16" W.C. in 1" Increments Including (1)-1/2 In. and (2)-1/4 In. W.C. Weights	Lead

**Expand-Seal min. pressure setting: 1.5 oz/in²

Table G - Seat & Pallet Material

Option G	Seat	Pallet
0	Standard*	Standard*
4	316 Stainless Steel	Standard*
5	Teflon Coated SS	Standard*
A	Aluminum	316 Stainless Steel
E	316 Stainless Steel	316 Stainless Steel
F	Teflon Coated SS	316 Stainless Steel

*See Materials of Construction
Options A-F are applicable for Aluminum bodies only. 316 SS Pallet is standard on all other body options.

Table H - LOX (Liquid Oxygen) & LIN (Liquid Nitrogen) Cleaning, Trim

Option H	Cleaning	Trim
0	Normal	Standard
1	LOX	Standard
2	LIN	Standard
5	Normal	316 Stainless Steel
6	LOX	316 Stainless Steel
7	LIN	316 Stainless Steel
8	Normal	Monel
9	LOX	Monel
A	LIN	Monel

For an ATEX Certified Valve choose Option 5, 6, 7. Trim includes Stem, Stem Guides, Side Guides, Nuts, Bolts, and Screen.

NOTE: LOX/LIN cleaning for Cryogenic Breathers of aluminum construction includes degreasing before assembly only!